

32" Widescreen LED Security Monitor



USER GUIDE



Contents

SAFETY	2
CAUTIONS.....	3
FCC RF INTERFERENCE STATEMENT	3
CONNECTING WITH EXTERNAL EQUIPMENT.....	4
CONTROLS AND FUNCTIONS.....	5-7
MOUNTING GUIDE	8
ACCESSORIES	8
POWER INDICATOR.....	9
DIMENSIONS	9
SPECIFICATIONS.....	10

Safety

1. Read these instructions completely and comply with all requirements.
2. Retain these instructions for reference.
3. Comply with all instructions and warnings, both in this manual and on the product.
4. Disconnect the monitor from all power before cleaning. Use a damp cloth for cleaning; and do not use liquid or aerosol cleaners.
5. Never use the monitor in damp areas or near water.
6. Never place the monitor on an unstable surface; if the monitor falls it may cause serious damage to people or property.
7. When selecting a location for placement/installation please insure:
 - A. To allow for sufficient ventilation leave a minimum distance of 4" around the monitor.
 - B. Never allow anything (e.g. paper, cloth, etc.) to obstruct the monitor ventilation openings.
 - C. Never allow an open flame source (e.g. lighted candles) near the monitor.
 - D. If batteries are used, please dispose of all batteries as per local regulations.
 - E. Use the monitor in indoor environments as per the temperature and humidity specs.
8. The monitor should be operated from a power source indicated on the rear of the monitor. If you are not sure of the type of power available, consult a licensed electrician.
9. The 3 wire grounding type plug [having a third (grounding) pin] used on this monitor is a safety feature. Do not power the monitor without the a grounding-type plug. If you are unable to insert the 3 wire plug into the outlet, contact your electrician to update the outlet.
10. Do not place the monitor where people will walk on the cord or allow anything to rest on or rub against the power cord.
11. If an extension cord is used to power the monitor, make sure that the total ampere usage of all the products plugged into the extension cord does not exceed the ampere rating of the extension cord nor the power rating of the outlet.
12. To avoid the risk of fire or an electric shock resulting from contact with dangerous voltage points or damage to parts, never insert objects of any kind into the monitor cabinet slots. Never spill any kind of liquid on the monitor.
13. Do not attempt to service this monitor yourself, as opening or removing the cover may expose you to dangerous voltage points or other risks. Refer all servicing to trained personnel.
14. If any of the following occur, disconnect the power to the monitor and refer servicing to qualified service personnel:

- A. When the power cord or plug is damaged or frayed.
- B. If liquid has been spilled into the monitor.
- C. If the monitor has been exposed to rain, water or other liquids.
- D. If the monitor does not operate as expected as per the operating instructions. Adjust only those controls as described in the operating instructions; improper adjustment of other controls may cause the monitor to become inoperative and may void the warranty.
- E. If the monitor has been dropped or the cabinet has been damaged.
- F. If the monitor exhibits a distinct change in performance, indicating a need for service.

PLEASE NOTE:

The power supply cord is used as the main disconnect device. Ensure that the power outlet is located/installed near the monitor and is easily accessible.

Cautions

► **NEVER REMOVE THE BACK COVER**

Only specially qualified personnel should remove the back cover.

► **DO NOT USE IN ENVIRONMENTS THAT MAY CAUSE HAZARDS**

To prevent electrical shock or a fire hazard, do not expose the monitor to rain or moisture. This monitor is designed to be used in the a residential or commercial environment. Do not subject the monitor to excessive vibration or dust, or to corrosive gases.

► **KEEP IN A WELL VENTILATED LOCATION**

Ventilation slots are provided on the cabinet to control the internal temperature of the monitor. Do not cover these ventilation holes or place anything on the unit which might block those slots.

► **AVOID EXCESSIVE HEAT**

Avoid placing the monitor in direct sunshine or near a heating appliance.

► **TO ELIMINATE EYE FATIGUE**

Do not use the monitor against a bright back ground or where sunlight and other light sources will shine directly on the monitor.

► **BE CAREFUL OF HEAVY OBJECTS**

Neither the monitor itself nor any other heavy object should rest on the power cord. Damage to a power cord can cause fire or electrical shock.

This equipment has been tested and found to comply with the limits for a Class B digital device, pursuant to Part 15 of the FCC Rules. These limits are designed to provide reasonable protection against harmful interference in a residential installation.

This equipment generates, uses, and can radiate radio frequency energy and, if not installed and used in accordance with the instructions, may cause harmful interference to radio communications. However, there is no guarantee that interference will not occur in a particular installation.

FCC RF Interference Statement

If this equipment causes harmful interference to radio or television reception, which can be determined by turning the equipment off and on, the user is encouraged to try to correct the interference by one or more of the following measures.

- Reorient or relocate the receiving antenna.
- Increase the space between the equipment and receiver.
- Connect the equipment into an outlet on a circuit different from that to which the receiver is connected.
- Consult the dealer, an experienced radio, or a TV technician for help.
- Only a shielded interface cable should be used.



Finally, any changes or modifications to the equipment by the user not expressly approved by the grantee or manufacturer could void the user's authority to operate such equipment.

► **DOC COMPLIANCE NOTICE**

This digital apparatus does not exceed the Class A limit for radio noise emissions from digital apparatus set out in the radio interference regulation of Canadian Department of Communications.

► **CE COMPLIANCE**

This monitor complies with the basic protection requirements of the Electromagnetic Compatibility (EMC) Directive 2004/108/EC for electrical and electronic equipment imported into the European Union (EU):
The electromagnetic disturbance generated by the apparatus does not exceed the level specified in the harmonized EMC Standards for this type of apparatus. It has a level of immunity to the electromagnetic disturbance to be expected in its intended use, and should operate without unacceptable degradation of its specified performance.



Connections

Back View of Monitor

Connector Panel is located on the underside of the case rear projection, just above the stand

Use **ONLY** a properly grounded three wire cord appropriate for the local power system.



► **Connector Panel(A)**

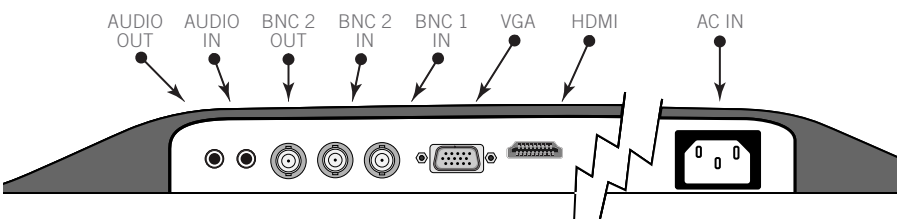

► **Power Switch(B)**

Power Switch can turn the monitor power off completely if it will not be used for an extended period of time



Controls & Menu Operation

CONTROL KEYS/BUTTONS

LED32 Buttons are located on the right underside of the bezel.

To change the input selection, press **SOURCE** to display the pop-up menu, use up/down to highlight the desired source, then press **MENU** to complete the selection.

To verify the current input selection, press **SOURCE** to display the pop-up, then press **SOURCE** again to dismiss the pop-up.



To close any OSD window, press **SOURCE** twice.

1. Image Parameters

The **PICTURE** menu is for adjusting the image appearance. The picture menu is for **BNC**. **PICTURE** menu options differ for **VGA**. Depending on **HDMI** signal format, either **PICTURE** menu form may be displayed

A. PICTURE Menu (BNC, & some HDMI)

Press the **MENU** button to bring the menu on screen, and then the up/down buttons to move up along the main menu selections to choose the **PICTURE** menu. Press the **SOURCE** button to move between the left side main menu selector into the window of menu choices and parameters.

Use the up & down buttons to move the yellow highlighted sub-menu selection within the sub-menu. Press the **SOURCE** button to enter the selected item, you can now use the up and down buttons to adjust the values. Press the **MENU** button to exit the sub-menu and return to the main menu selector.

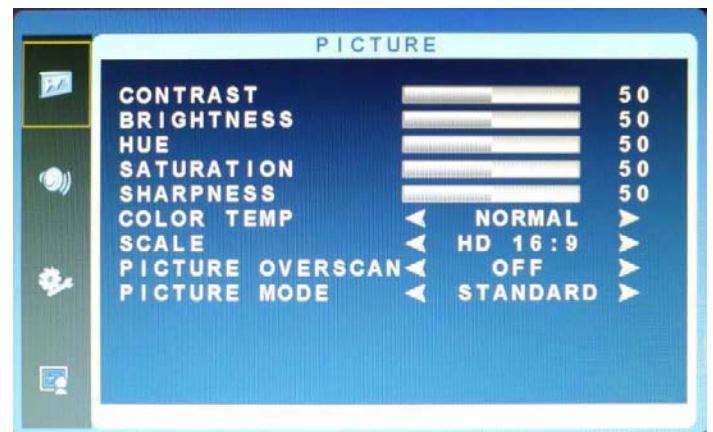

To exit the menu system, press the **MENU** button twice. Settings will remain as they appear on screen.

Adjustments

Contrast: Adjusts the range of difference between light and dark areas of the picture.

Brightness: Adjusts the overall picture intensity.

Hue: Increase or decrease the red/green/blue tint of the image.

Saturation: Increase or decrease the intensity of (mix of white with) colors in the image.

Sharpness: Change the balance between image detail (Resolution) and degree of transition between areas of differing brightness (Acutance).

Color Temp: Adjust color reproduction: choose between **normal**, **warm** (more red) & **cool** (more blue) to achieve the best visual result.

Scale: Choose between SD 4:3 and HD 16:9 aspect ratio. If analog images appear 'stretched' use 4:3 scaling.

Picture Overscan: Choose between legacy CRT-type cropping of picture edges (**On**) or display of entire image without cropping (**Off**). Note: HDMI recognizes multiple signal types; for some types of HDMI signals Overscan is disabled.

Picture Mode: Choose from Standard/Movie/Vivid/User for most pleasing image based on ambient light. User mode

stores custom adjustments to contrast/brightness/hue/saturation/sharpness.

B. Picture Menu for VGA and some HDMI

Adjustments

Contrast: Adjusts the contrast between light and dark areas of the picture.

Brightness: Adjusts the overall picture shade and brightness.

Color Temp: To adjust color reproduction choose between **normal**, **warm** (more red) & **cool** (more blue).

Scale: Choose between SD 4:3 and HD 16:9 aspect ratio



2. AUDIO MENU

Press the MENU button to bring the menu on screen, and then up/down buttons to move along the menu selections to highlight the AUDIO menu. Press the SOURCE button again to move between the left side main menu selector into the window of menu choices and parameters.

Use the up & down buttons to move the yellow highlighted sub-menu selection within the sub-menu. Press the SOURCE button to enter the selected item, you can now use the up and down buttons to adjust the values. Press the MENU button to exit the sub-menu and return to the main menu selector.

To exit the menu system, press the MENU button twice.

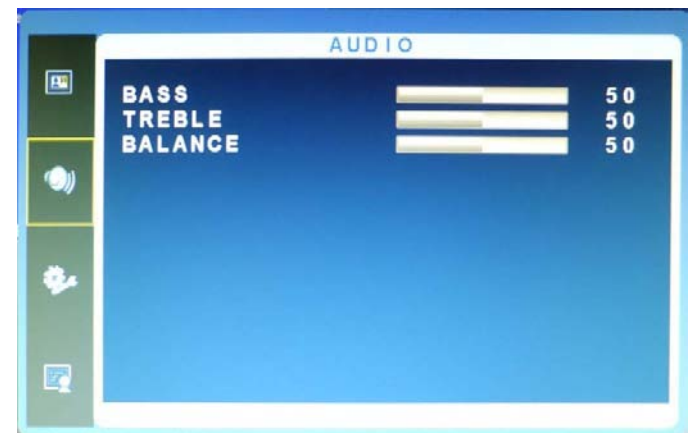

Adjustments

Bass: Boost/limit low frequency tones.

Treble: Boost/limit high frequency tones.

Balance: Change relative volume between left and right speakers.

3. OSD Menu

Press the MENU button to bring the menu on screen, and then up/down buttons to move along the menu selections to highlight the OSD menu. Press the SOURCE button again to move between the left side main menu selector into the window of menu choices and parameters.

Use the up & down buttons to move the yellow highlighted sub-menu selection within the sub-menu. Press the SOURCE button to enter the selected item, you can now use the up and down buttons to adjust the values. Press the MENU button to exit the sub-menu and return to the main menu selector.

To exit the menu system, press the MENU button twice.

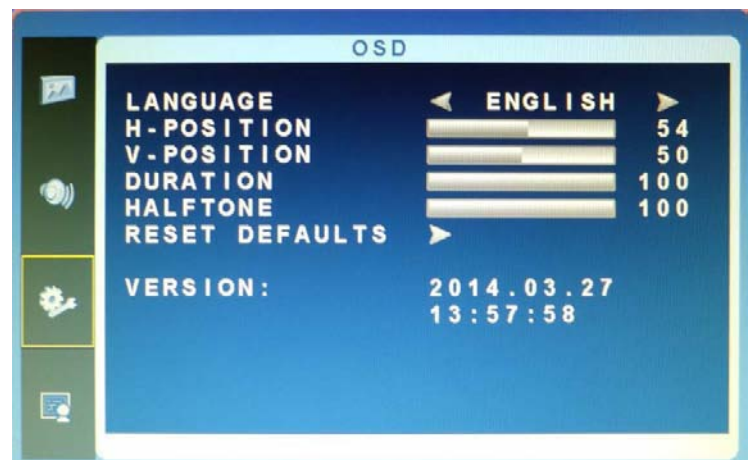

Adjustments

Language: Choose OSD display language from English/Chinese/German/French/Spanish/Italian.

H-Position: OSD horizontal position on the screen.

V-Position: OSD vertical position on screen.

Duration: OSD Menu timeout.

Halftone: OSD Menu background opacity (allows viewing of the video behind the OSD menu).

Reset Defaults: Restore monitor to factory default settings.

Version: Displays firmware version number (not adjustable).

4. FUNCTION/GEOMETRY MENU

The HDMI, and BNC inputs share the FUNCTION menu. The VGA menu is labeled GEOMETRY

A. FUNCTION Menu

Press the MENU button to bring the menu on screen, and then up/down buttons to move along the menu selections to highlight the FUNCTION menu. Press the SOURCE button again to move between the left side main menu selector into the window of menu choices and parameters.

Use the up & down buttons to move the yellow highlighted sub-menu selection within the sub-menu. Press the SOURCE button to enter the selected item, you can now use the up and down buttons to adjust the values. Press the MENU button to exit the sub-menu and return to the main menu selector.

To exit the menu system, press the MENU button twice.



Adjustments

DLC: Dynamic Light Control On/Off Limits the brightness/contrast ratio extremes in on screen video.

B. GEOMETRY Menu (VGA Only) Press the MENU button to bring the menu on screen, and then up/down buttons to move along the menu selections to highlight the GEOMETRY menu. Press the SOURCE button again to move between the left side main menu selector into the window of menu choices and parameters. Use the up & down buttons to move the yellow highlighted sub-menu selection within the sub-menu. Press the SOURCE button to enter the selected item, you can now use the up and down buttons to adjust the values. Press the MENU button to exit the sub-menu and return to the main menu selector. To exit the menu system, press the MENU button twice.

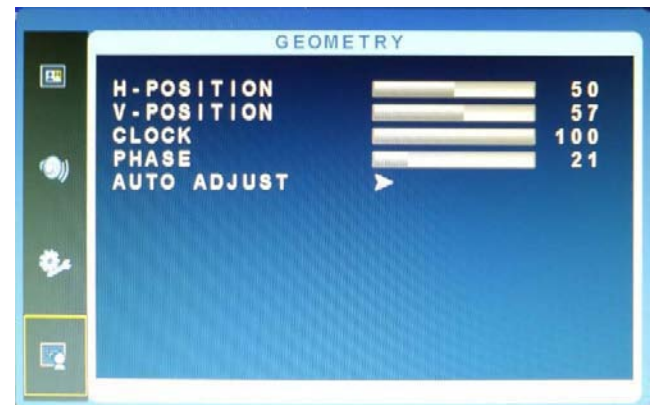

Adjustments

H-Position: Image Horizontal position

V-Position: Image Vertical position

Clock: Relative adjustment of horizontal scan rate

Phase: Relative adjustment of synch

Auto Adjust: Press SOURCE button to automatically adjust settings to match input signal parameters

Mounting Guide

CAUTION: The wall mount must bear a minimum of five times the monitor's net weight. To mount your MONITOR to the wall or another surface, you need to purchase a VESA wall mount. Use four M4 x 8mm screws (the base attachment screws removed in step 1 below are M4 x 8mm) to attach the mount. The monitor mount VESA hole pattern is 100mm x 100mm. **Note:** Metric (M4 x 8 mm) is the type screw that should be used (do not use longer screws or the monitor may be damaged).

For LED32

1. Before mounting the monitor, remove the base riser (vertical portion of the base) by removing the four screws near the top with a screwdriver. Then the base and the riser can be removed. In order to prevent losing these screws, we suggest retaining the screws if re-attaching the base is needed at a later time.

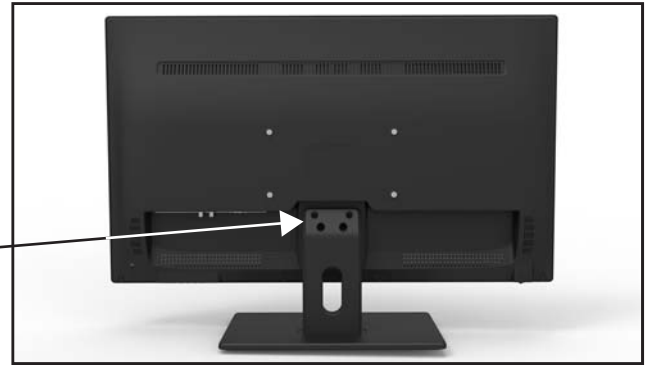

2. Attach the VESA mount (200mm x 100mm) plate to the rear of the monitor and follow all of the instructions provided with the mount to complete the mounting process.

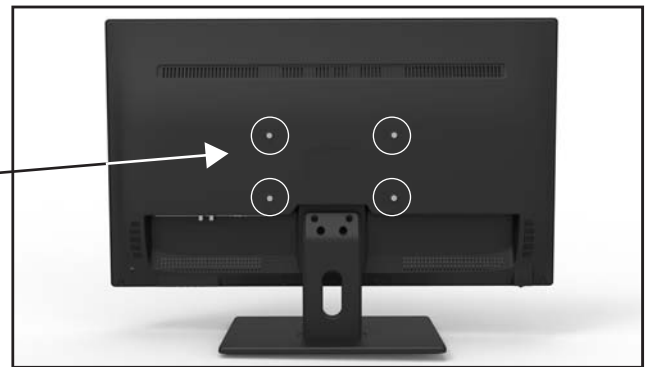

Accessories



Power Cord



HDMI Cable



VGA Cable



Audio Cable

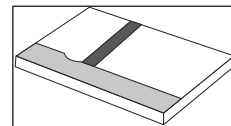

User Guide



IR Remote Control

Power Indicator/Modes of Operation

LED INDICATOR

LED is off when power is off; LED glows green when power is on. The power management feature of the monitor is designed for security surveillance applications. When there is no video, the monitor remains ON to be instantly ready to display video when the source is changed or if a PC changes state from sleep/standby to active mode. A floating "No Signal" box moves slowly across the screen until video is restored.

Dimensions

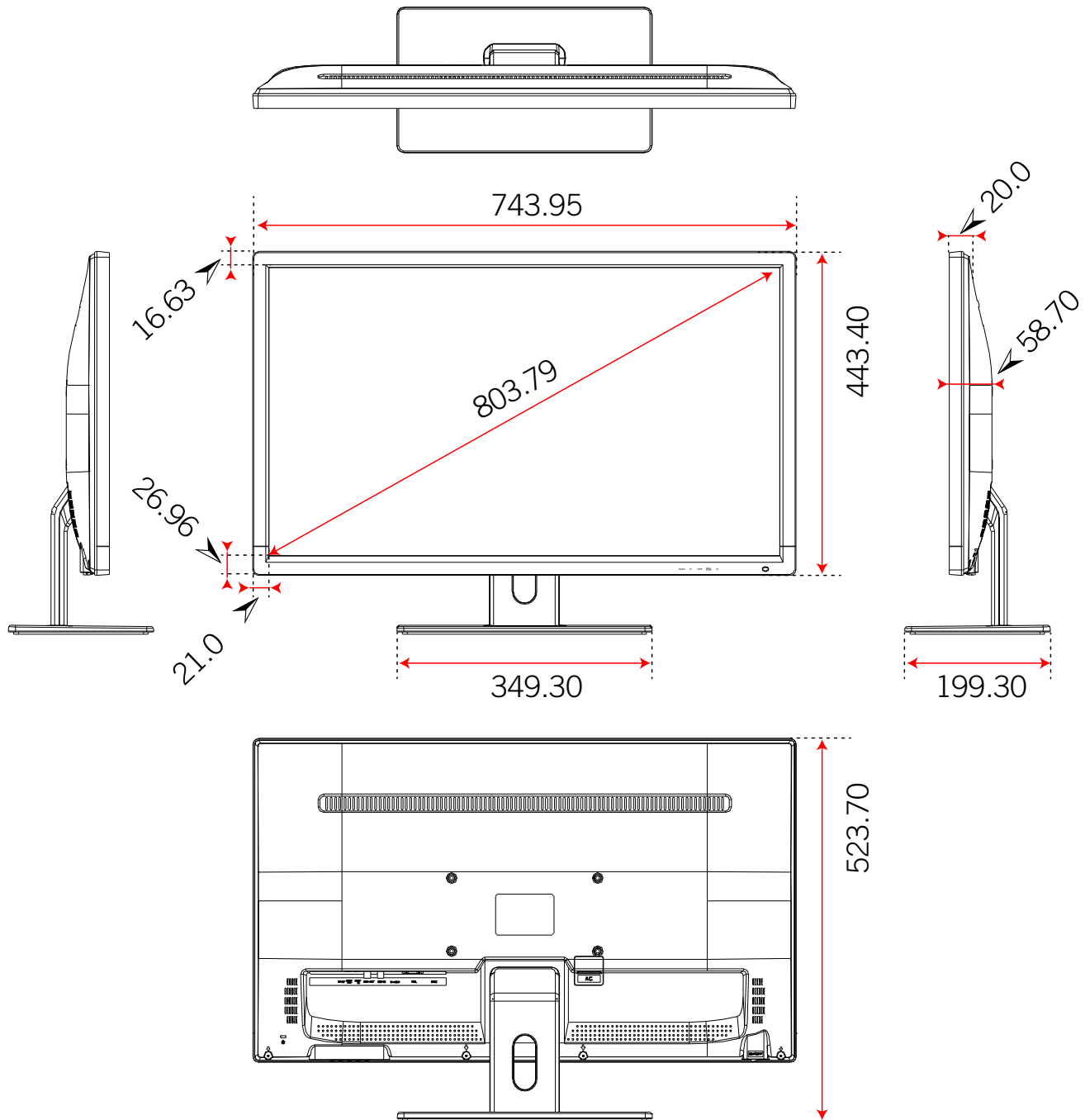

Specifications LED32

SPECIFICATION	LED32
Video System	NTSC/PAL (Auto Sensing)
Max Resolution	1920x1080 (Native)
Supported Resolutions	720x400; 640x480; 800x600; 1024x768; 1280x1024; 1366x768; 1440x900; 1600x900; 1680x1050; 1920x1080
3D Comb Filter	Yes
3D De-Interlace	Yes
OSD (On Screen Display)	Yes
Backlight	LED
Active Display Area	32" Diagonal
Impedance	75 OHM Self Terminating
Video Input Signals	HDMI, VGA, Composite BNC
Aspect Ratio	Selectable 16:9 or 4:3 in OSD
Pixel Pitch	0.364mm
Color Depth	24 bits, 16.7 Million colors
Brightness	300 cd/m ²
Contrast Ratio	3000:1
Viewing Angle (H/V)	178°/178°
Response Time	6.5ms
Auto Adjustment	Yes
Certificates	CE,FCC, UL
Languages	English, Chinese, German, French, Spanish, Italian
Input Voltage	100 ~ 240V AC
Power Consumption	<55W
Video Connections	HDMI, VGA, BNC 1 Input, BNC 2 Input/Output
Audio Connections	PC Audio (3.5mm Stereo) for VGA & BNC Input
Speakers	8Ω, 3 Watt per Channel
Dimensions (with stand) (H x W x D)	20.63" x 29.13" x 7.75"
Weight	17.6 lb
Vesa Mounting	Yes (200 x 100)
Operating Temperature	32° ~ 104°(0°C ~ 40°C)