

FEATURES

- Junction box for N2IPPTZ30X & HDPTZ33X
- Heavy Duty Aluminum Construction
- Hinged Door for Easy Installation
- Compatible with:
N2IPPTZ30X & HDPTZ33X Wall Mount Arm (Incl. with Camera)
N2PTZCRNMT (Corner Mount)
N2PTZPOLEMT (Pole Mount)



N2PTZJB

SUPPORTED MODELS

For N2IPPTZ30X & HDPTZ33X Wall Mount

DIMENSIONS

Shown with included wall mount for N2IPPTZ30X & HDPTZ33X below.

SPECIFICATIONS

General	
Material	Heavy Duty Aluminum
Color	White
Product Dimensions	396.5(L) x 209.2(W) x 310(H)mm / 15.6”(L) x 8.2”(W) x 12.2”(H)
Product Weight	3125g / 6.9lb
Max Bearing Weight	10kg / 22lb

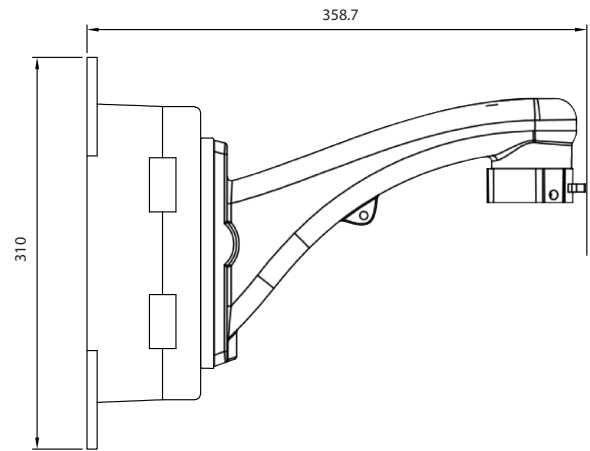

HOLE MARKINGS & DIMENSIONS

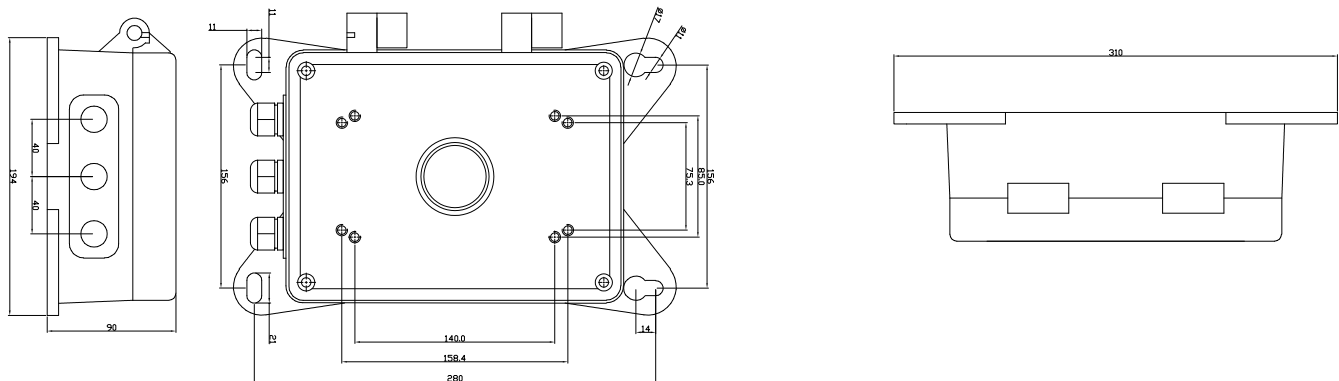

* All specifications subject to change without notice for quality improvement