

## Junction Box for Select Cameras

FOR USE WITH CAMERA MODELS:

N2IP4T, HDTIR90WD



N2JB3



Shown with HDTIR90WD  
(Camera not included)

### FEATURES:

- Manages & Protects Cables
- 3/4" Conduit Access
- For Indoor & Outdoor Use

### SPECIFICATIONS:

|                    | N2JB3                       |
|--------------------|-----------------------------|
| Material           | Aluminum Alloy              |
| Color              | White                       |
| Load Bearing       | 3 kg (6.61 Lb.)             |
| Product Dimensions | φ117 x 46mm (φ4.21 × 1.81") |
| Product Weight     | 0.34kg (0.75 Lb.)           |

### PACKAGE INCLUDES:

| Item                                  | Qty |
|---------------------------------------|-----|
| Junction box                          | 1   |
| 3/4" Conduit Caps                     | 2   |
| Plastic Conduit Cable Connector       | 1   |
| Rubber Grommet (for cable φ4.5~5.5mm) | 1   |
| Rubber Grommet (for cable φ6~8mm)     | 1   |
| Black Rubber Plug                     | 1   |
| Mounting Template                     | 1   |
| Torx Screws M4×18mm                   | 3   |
| Torx Wrench                           | 1   |
| Mounting Hardware Packet              | 1   |

### DIMENSIONS:

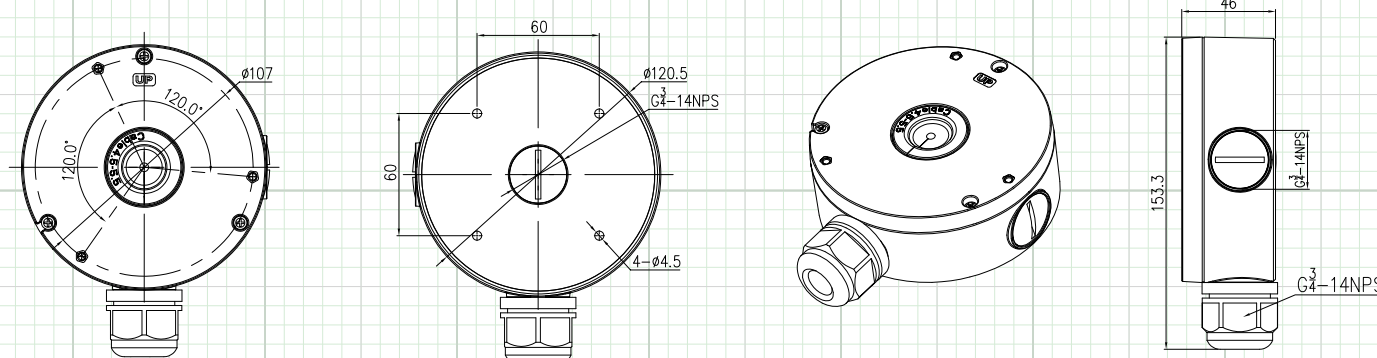

Note: Specification subject to change without notice