

FOR CAMERAS

N2IP4AFD
 HDAFDIR90WD
 HDAFDIR90INWD



SPECIFICATIONS

General	
Material	Aluminum
Color	White
Operating Humidity	0% - 90% RH
Product Dimensions	215mm x 140mm x 107mm
Product Weight	565g

DIMENSIONS

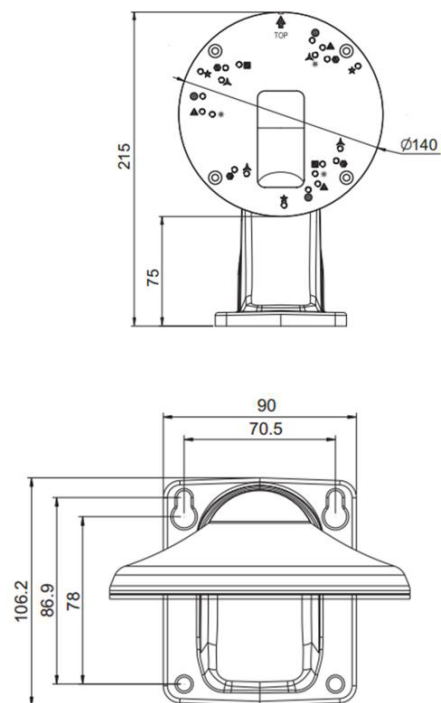

MOUNT COMPATIBILITY

Camera Model	Screw Size	N2WMAFD Hole Markings
N2IP4AFD	PM4*6MM	•
HDAFDIR90WD	PM4*6MM	•
HDAFDIR90INWD	PM4*6MM	•

HOLE MARKINGS

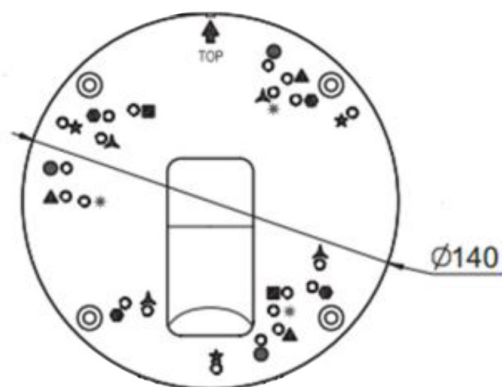

* All specifications subject to change without notice for quality improvement

ABOUT THIS BRACKET – Read Before Use

1. Before installation, please check the bracket packing and accessories are intact. If the bracket is damaged or missing accessories please contact us at 855-388-7422 or email us at info@northernvideo.com.
2. Do not exceed the MAX load listed on the bracket label.
3. Check the installation area and make sure it will support the total weight of the installed product and bracket.
4. Bracket ships with installation screws, check the material the bracket will be installed onto and use appropriate screws based on the material (may not be supplied with bracket).
5. If the bracket is installed near the ocean or areas exposed to heavy chemicals corrosion may occur which can affect the strength of the bracket. Check the bracket regularly for corrosion.